

BV25063 | PN25 EN 1092-2

Nodular Cast Iron EN-GJS-400-18-LT

Temperature min. -10°C
Temperature max. +350°C



Testing pressure in bar

Hydro	Body	37,5
	Seat	27,5
Air	Seat	07

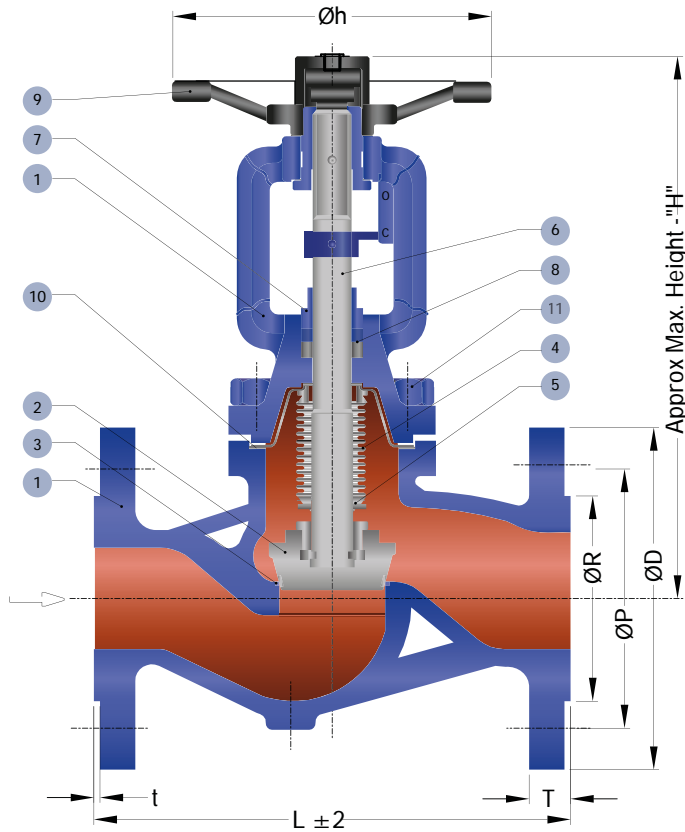

N°	COMPONENT	MATERIALS
1	Body & Bonnet	EN-GJS-400-18-LT Nodular Cast Iron
2	Plug	St. Steel 1.4021 + Hard Faced 13% Cr
3	Seat	ASTM - A105 + Hard Faced 13% Cr
4	Bellow	St. Steel 1.4541 / AISI-321
5	Bellow collar	St. Steel 1.4541
6	Stem	St. Steel 1.4006
7	Gland	St. Steel 1.4021
8	Packing	Pure Graphite
9	Hand Wheel	EN-GJS-400-18-LT Nodular
10	Bonnet Gasket	Graphite + Stainless steel
11	Bolt & Nuts	Carbon Steel Gr.10.9

ZERO LEAKAGE
DIN: Rate A acc. EN12266-1

Face to face dimensions acc. to EN558-1
Flanges acc. to EN 1092-2 form B

DN	PN	ØD (outer flange diameter)	ØP (Bolt circle)	ØR	T (FGL.THK)	t	NO.OF HOLE / Ø	L (Face to face)	Øh	STROKE	H (closed)	Weight (Kg)
15	25	95	65	46	16	2	4/Ø14	130	150	4	215	5,00
20	25	105	75	56	18	2	4/Ø14	150	150	5	220	5,50
25	25	115	85	65	19	3	4/Ø14	160	150	6.5	230	6,40
32	25	140	100	76	19	3	4/Ø19	180	150	8	235	8,30
40	25	150	110	84	19	3	4/Ø19	200	200	10	260	14,20
50	25	165	125	99	20	3	4/Ø19	230	200	13	265	14,14
65	25	185	145	118	22	3	8/Ø19	290	250	16,5	325	24,80
80	25	200	160	132	24	3	8/Ø19	310	250	20	355	27,90
100	25	235	190	156	24	3	8/Ø23	350	300	25	410	42,20
125	25	270	220	184	26	3	8/Ø28	400	350	32	450	67,00
150	25	300	250	211	28	3	8/Ø28	480	400	38	525	91,00
200	25	360	310	274	34	3	12/Ø28	600	450	51	645	147,00

all dimensions in mm.

WORKING CONDITIONS						
Temperature °C	-10/120	150	200	250	300	350
Pressure Bar	25	24,3	23	21,8	20	17,5